

CONSEW® Since 1898

MODELS 5457R / 5457R-3 / 5457R-43

WITH
 HORIZONTAL AXIS TRANSVERSE ROTARY HOOK
 AUTOMATIC LUBRICATION
 REVERSE FEED
 BUILT IN BOBBIN WINDER
 ROTARY TAKE-UP

Model 5457R-43



Model 5457R

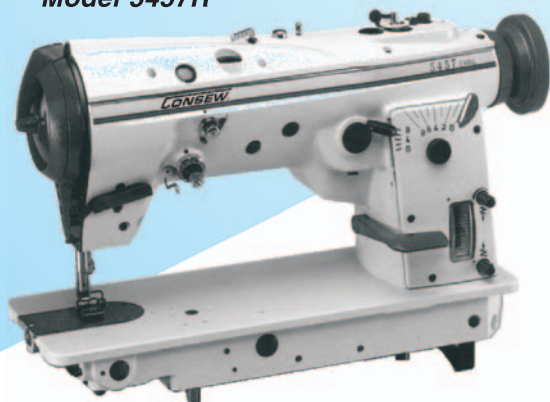

ULTRA HIGH SPEED
 SINGLE NEEDLE
 DROP FEED
 ROTARY TAKE-UP ZIG-ZAG
 LOCKSTITCH MACHINE

ZIG ZAG

Model 5457R / 5457R-3 / 5457R-43

APPLICATIONS

- For sewing light to medium-heavy weight fabrics
- For use with such products as foundation garments, brassieres, underwear, apparel and accessory groups
- Model 5457R (2 step/1 stitch) Standard Zig-Zag, Federal stitch number 304.
- Model 5457R-3 (4 step/3 stitch) Elastic seaming and attaching elastic straps to corsets, bras, and waist sections
- Model 5457R-43 (4 step/3 stitch cam is standard. All others are optional.) For scallop and blindstitch stitching as well as regular zig-zag stitching

FEATURES

- Automatic lubrication
- Horizontal axis transverse rotary hook
- Zig-zag stitch at center position or either to left or right of center position
- Stitches per minute - 5000* (Model 5457R-43 – 4000 S.P.M.*)
- Reverse stitching
- Dial-type zig-zag width adjustment
- Rotary take-up lever
- Dial-type feed adjustment
- Needle position adjustment by lever
- Model 5457R-43 – interchangeable pattern stitch cams (call for design specifications)



SPECIFICATIONS

Speed, Max. (S.P.M.)*	5000*	Bobbin	Metal	2130504-321
{Speed, Max. (S.P.M.)* Model 5457R-43	4000*}		Pre-wound	F
Clearance Under Foot	1/4" (6.35mm)	Hook		2130504-310
Needle Bar Stroke	1 3/16" (33mm)	Bed Size	7" x 18 7/8" (178 x 478 mm)	
Stitch Length, Max.	Model 5457R	Work Space	10" (255mm)	
	Model 5457R-3	Stitch Width, Max.	5/16 (8 mm)	
Needle	1906-1	Stitch Type	304 (standard 1-stitch)	

* Speed depends on operation, materials and thread